

ULINE

**INDESTRUCTO
MAILER**

1-800-295-5510
uline.com

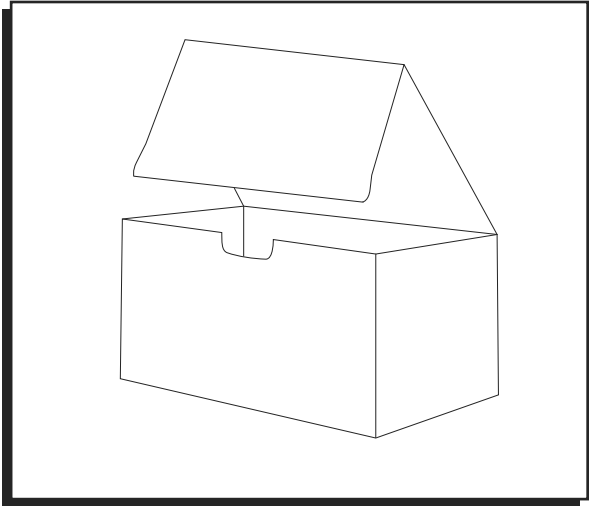

ASSEMBLY

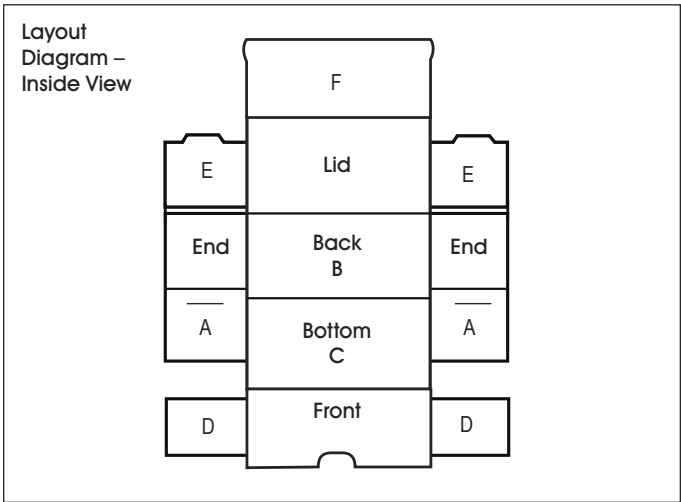

1. Fold flaps A straight up and then into center. (See Figures 1-2)

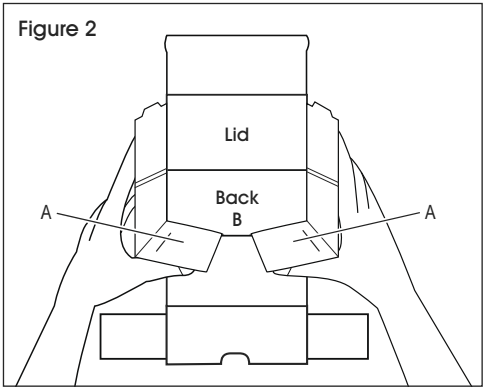
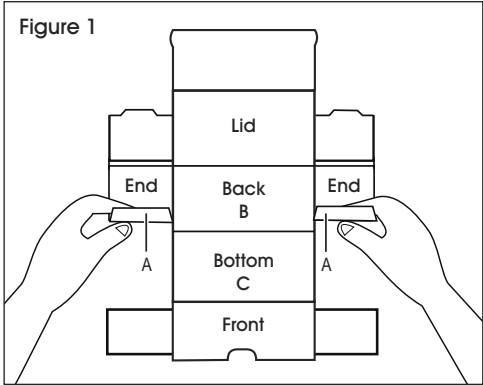

TO DETERMINE INSIDE VIEW:

- NOTE:** If the item number is printed (on panel D), print should face down.
- NOTE:** If the item number is pinned/embossed (on panel C), the item number should face up.

ASSEMBLY CONTINUED

2. Fold bottom panel C up and fold flaps D so they go inside the ends. (See Figures 3-4)

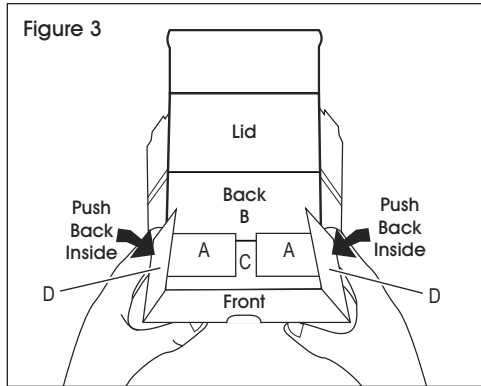

3. Fold locking tabs E down and lock into bottom. (See Figures 5-6)

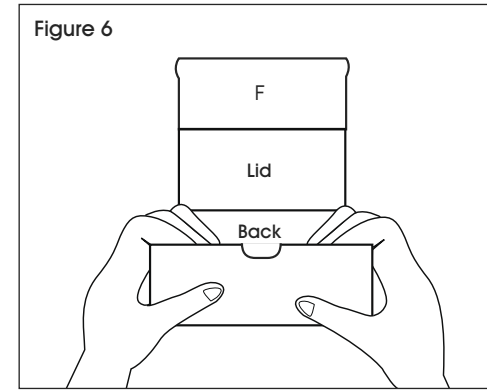
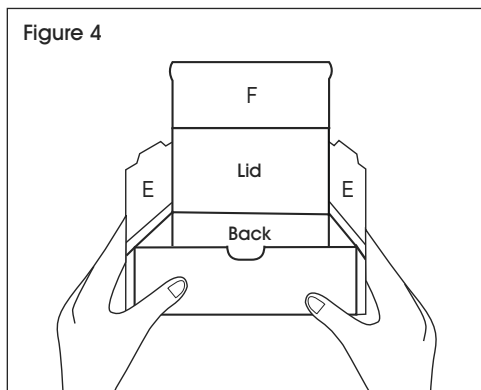
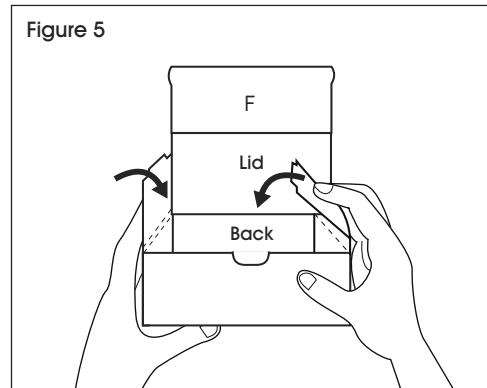

4. Fold down lid and tuck panel F into mailer to close. (See Figure 7)

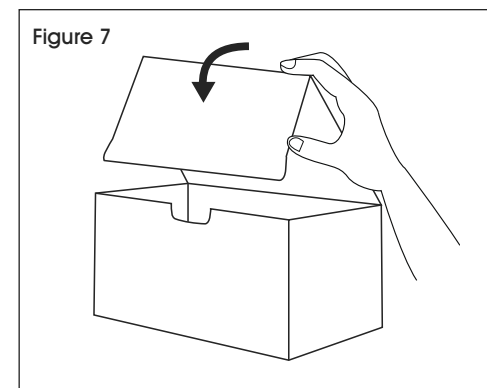

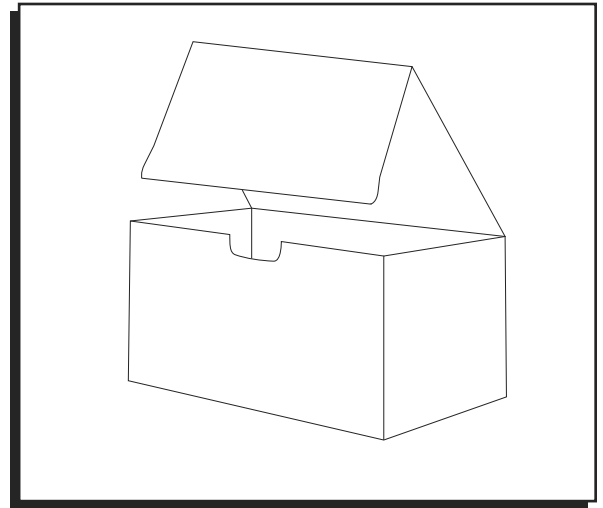
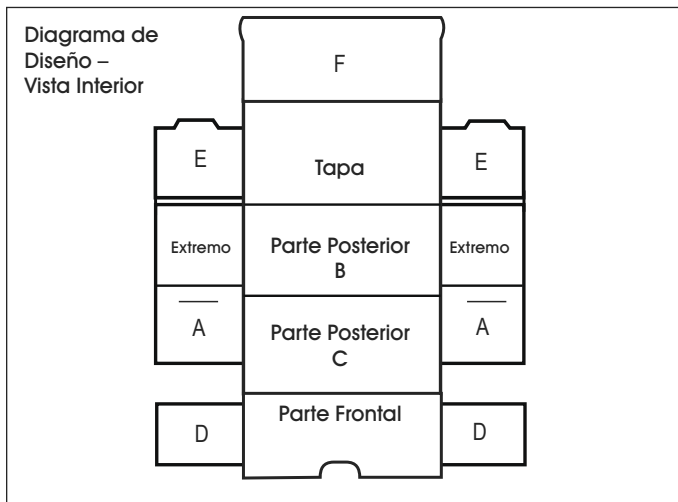
**ENSAMBLE**

1. Doble las solapas A hacia arriba y luego hacia el centro. (Vea Diagramas 1-2)

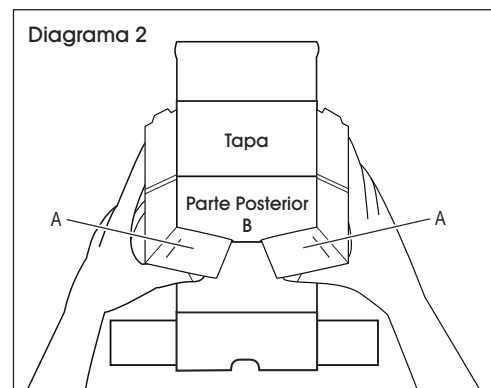
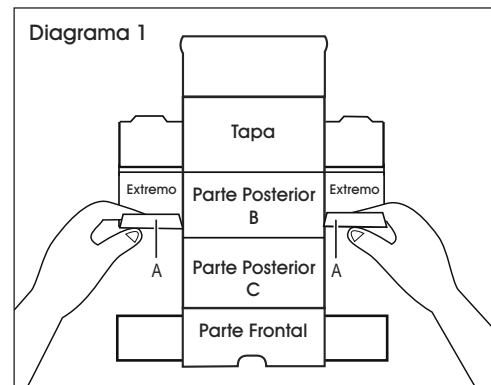
**PARA DETERMINAR LA VISTA INTERIOR:**

NOTA: Si el número del artículo está impreso (en el panel D), la impresión va hacia abajo.



NOTA: Si el número del artículo está grabado en relieve (en el panel C), el número del artículo debe quedar hacia arriba.

CONTINUACIÓN DE ENSAMBLE

2. Doble la parte posterior panel C hacia arriba y doble las solapas D para que vayan adentro de los extremos. (Vea Diagramas 3-4)

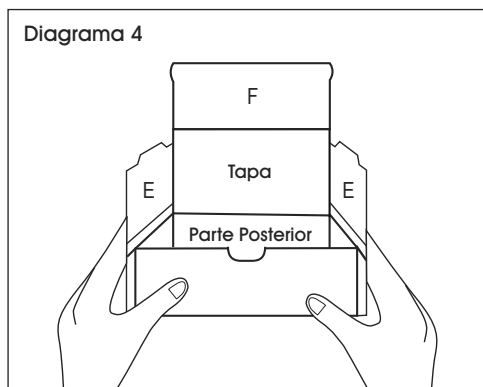
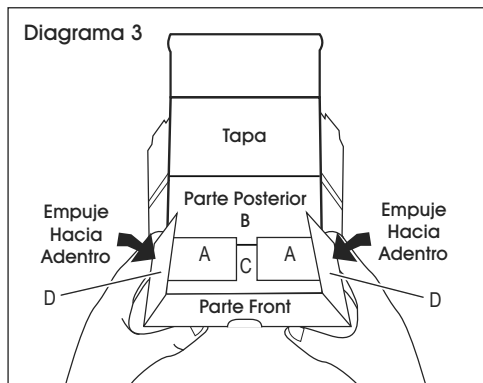

3. Doble las pestañas de cierre E hacia abajo y asegúrelas en la parte inferior. (Vea Diagramas 5-6)

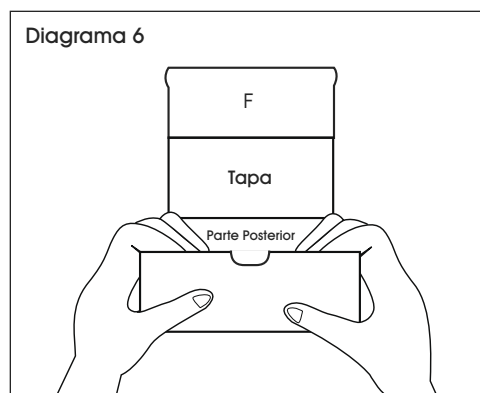
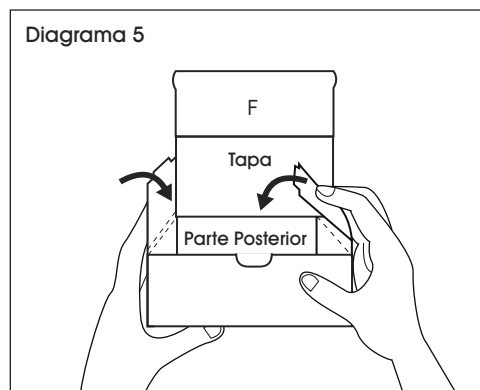

4. Doble la tapa hacia abajo y ajuste el panel F dentro de la caja para cerrarla. (Vea Diagrama 7)

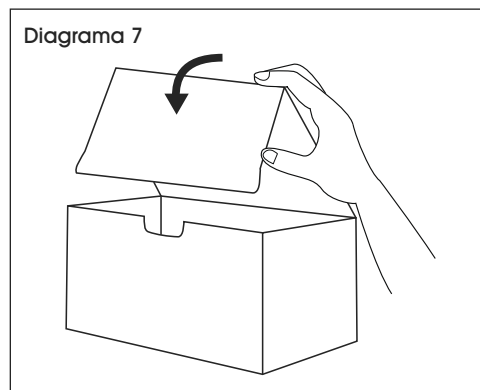

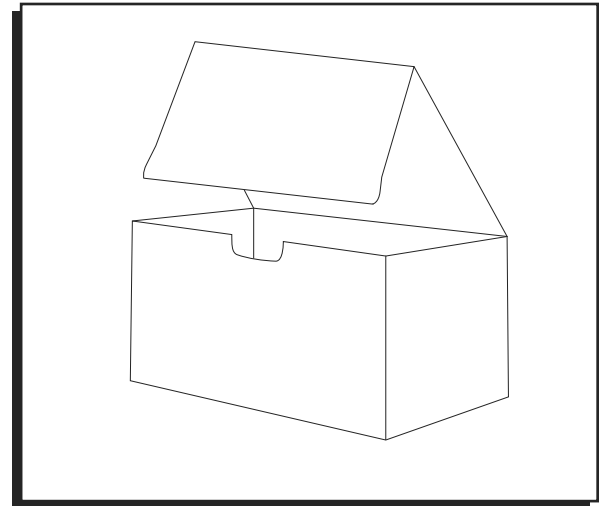
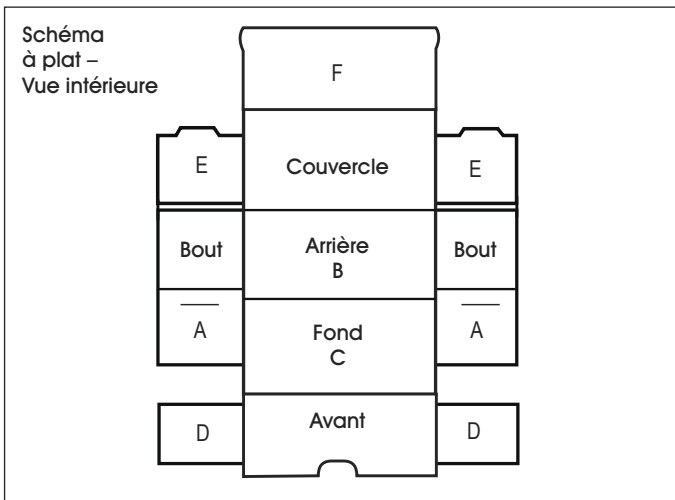
**ASSEMBLAGE**

1. Pliez les rabats A vers le haut et ensuite vers le centre. (Voir Figures 1-2)

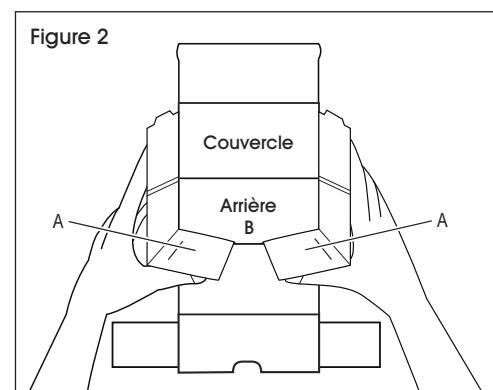
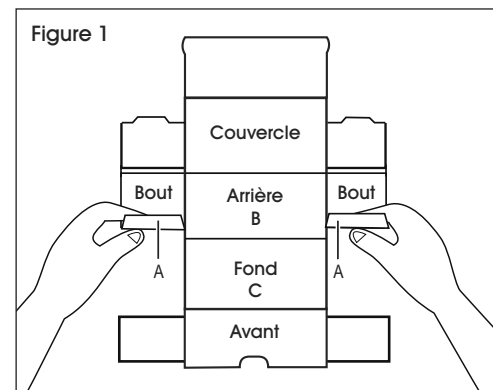
**POUR DÉTERMINER LA VUE INTÉRIEURE :**

REMARQUE : Si le numéro d'article est imprimé (sur le panneau D), le côté imprimé doit être orienté vers le bas.



REMARQUE : Si le numéro d'article est épinglé ou estampé (sur le panneau C), le numéro d'article doit être orienté vers le haut.

ASSEMBLAGE SUITE

2. Pliez la paroi du fond C vers le haut et les rabats D de manière à ce qu'ils s'insèrent dans les fentes de la paroi du bout. (Voir Figures 3-4)

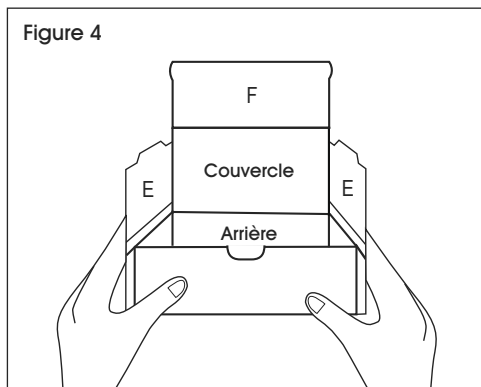
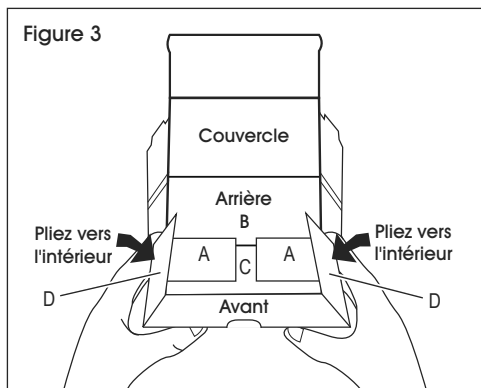

3. Pliez les languettes de fermeture E vers le bas et sécurisez-les au fond. (Voir Figures 5-6)

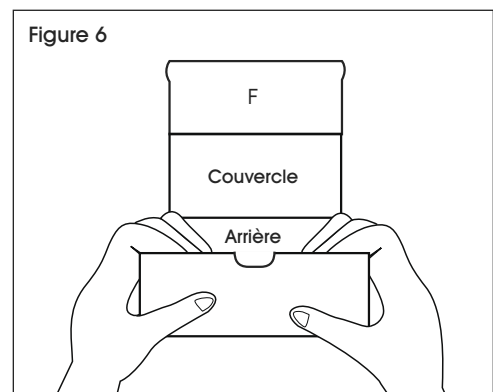
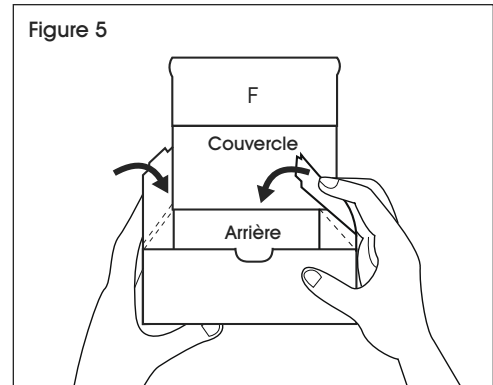

4. Pliez le dessus de la boîte et insérez la languette F à l'intérieur de la boîte pour la fermer. (Voir Figure 7)

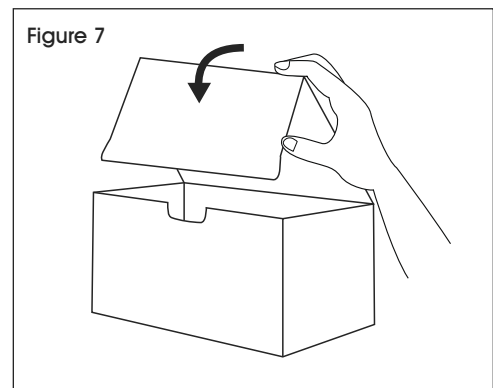

ULINE

1 800 295-5510
uline.ca